

Plane of foundation  
Fundamentplan  
Plan de fondation  
Schema fondazioni

### STANDARD D400

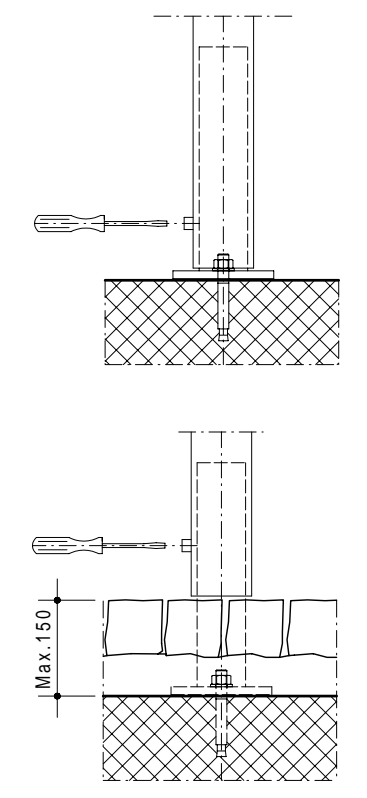
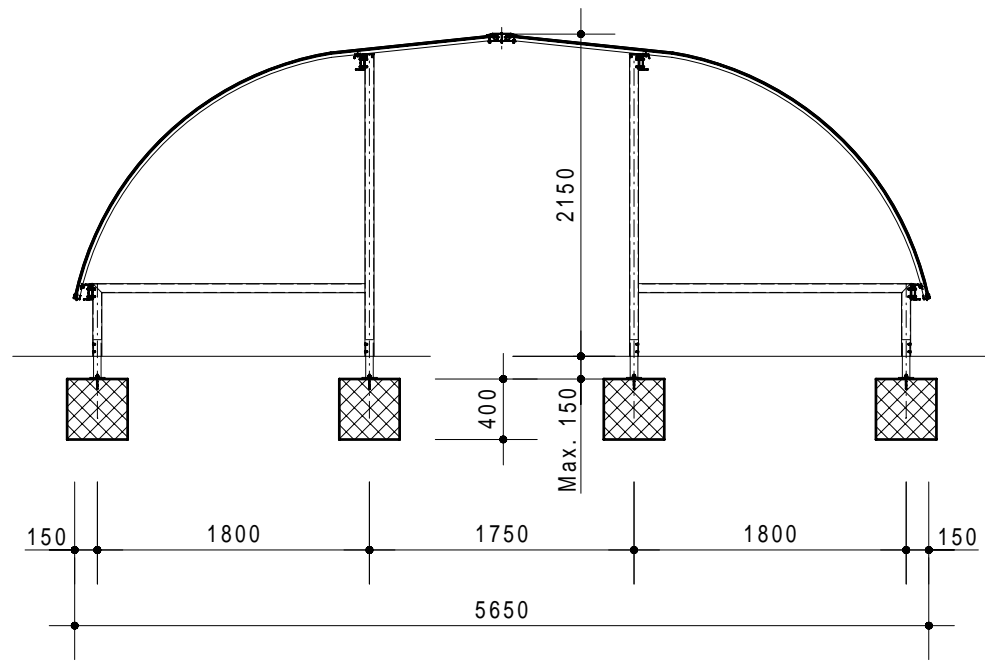

ON REQUEST - AUS ANFRAGE - SUR DEMANDE - SU RICHIESTA

Wall side - Seitenwände  
Finition laterales - Pareti laterali

Holder - Velohalter  
Support - Supporti

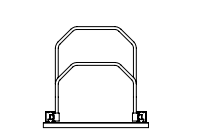
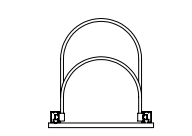
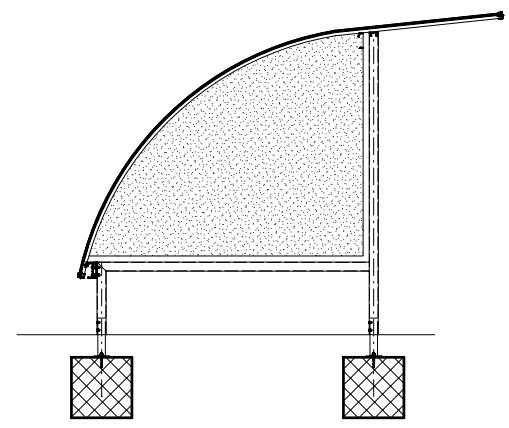

Mod. H-14 15

Mod. H-16 17

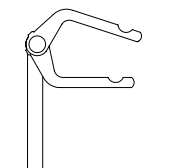
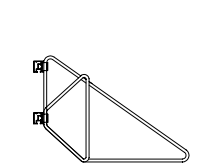

Mod. D-12 13

Mod. M20

Trattamento: Ferro zincato a bagno	Alu ossidato naturale	N° pezzi
Committente:		N° ordine
Modello: STANDARD D	Materiale: FERRO - STAHL	Data: Sett. 05
Descrizione COPERTURA CICLI E MOTOCICLI " STANDARD D "		Disegnato: GB
ÜBERDACHUNGEN FAHRRÄDER UND MOTORRÄDER " Standard D "		Scala: ---

**KERNAG SA** FÜR VERKEHRSSICHERHEIT  
POUR SÉCURITÉ DE TRAFIC

Weberrütistrasse 9  
8833 Samstagern  
T 044 783 22 88 F 044 783 22 87  
info@kernag.ch www.kernag.ch

N° dis. / Articolo

# STANDARD D400