

Plane of foundation
Fundamentplan
Plan de fondation
Schema fondazioni

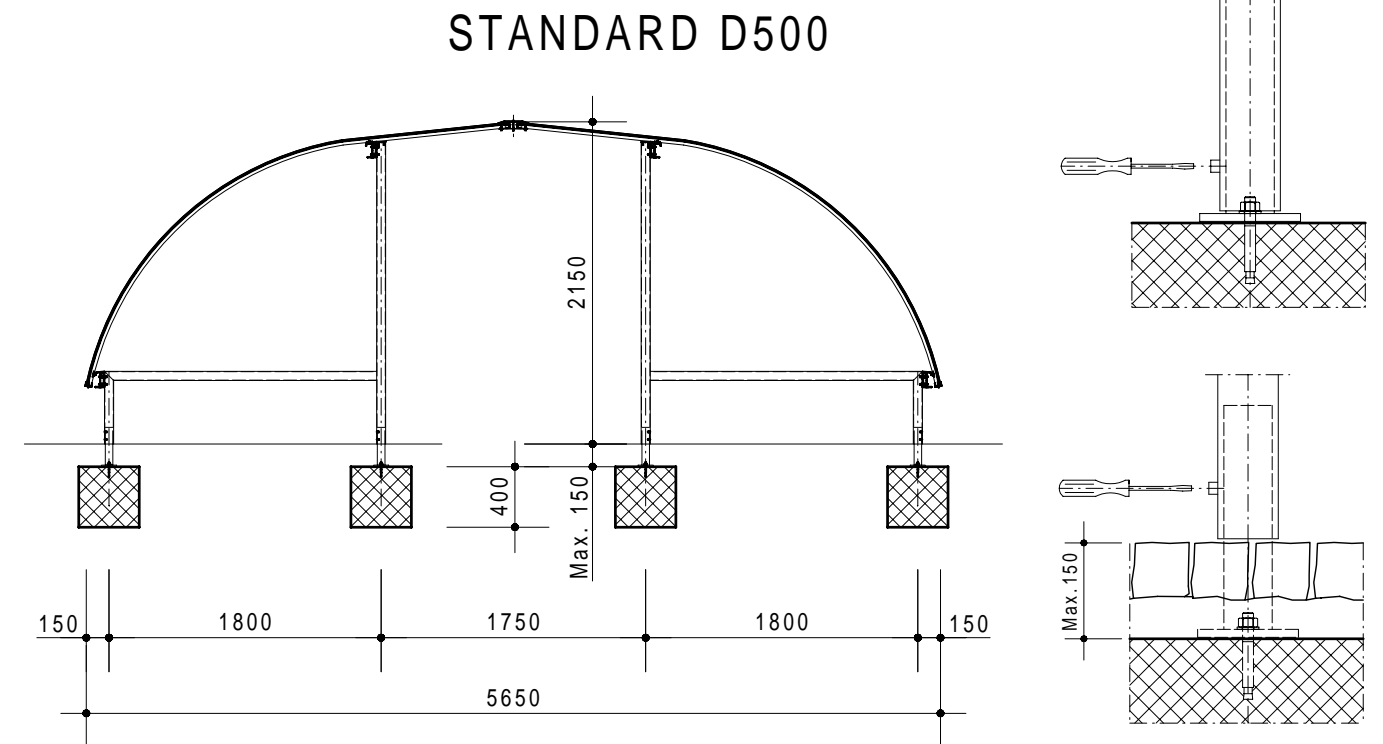

ON REQUEST - AUS ANFRAGE - SUR DEMANDE - SU RICHIESTA

Wall side - Seitenwände
Finition laterales - Pareti laterali

Holder - Velohalter
Support - Supporti

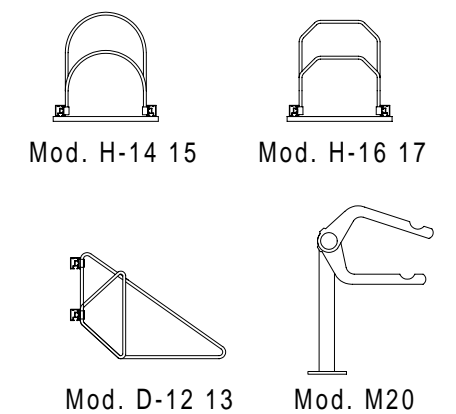
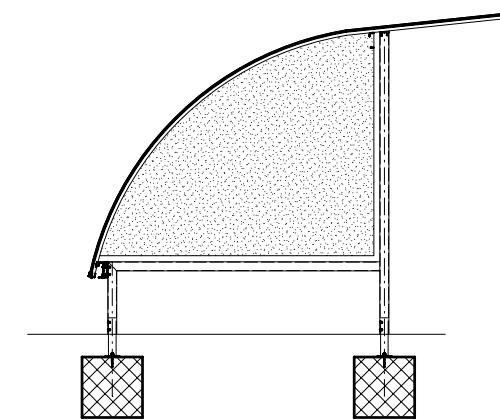

Trattamento: Ferro zincato a bagno		Alu ossidato naturale	N° pezzi
Committente:			N° ordine
Modello: STANDARD D	Materiale: FERRO - STAHL		Data: Sett. 05
Descrizione COPERTURA CICLI E MOTOCICLI " STANDARD D "			Disegnato: GB
ÜBERDACHUNGEN FAHRRADRÄDER UND MOTORRÄDER " Standard D "			
N° dis. / Articolo		STANDARD D500	



Weberrütstrasse 9
8833 Samstagern
T 044 783 22 88 F 044 783 22 87
info@kernag.ch www.kernag.ch